



NEW GENERATION
HIGH QUALITY TOP ROLLERS

DRAW FRAME / COMBER
LAP FORMER / RING FRAME ARBORS
SPEED FRAME & COMPACT SPINNING ARBORS

MAINTENANCE FREE & LOW HEAT - END BUSHES

- ❖ New Design - Improved life
- ❖ Imported Bearings — INA - Germany
IKO - JAPAN

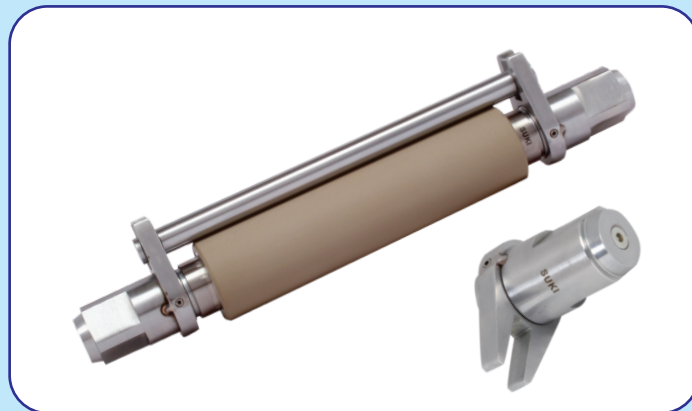
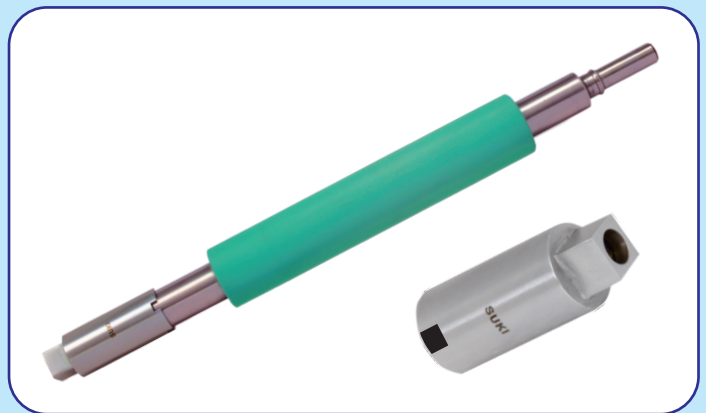

WORLD CLASS TOP ROLLERS FOR ALL LEADING PREPARATORY MACHINES

SUKI TEXPARTS PRIVATE LIMITED

Quality

Perfection

TOP ROLLERS - PREPARATORY - Compatible for following Models

DRAW FRAME M/C. MODELS	COMBER DETACHING & COMBER DRAW BOX M/C. MODELS	LAP FORMERS M/C. MODELS
RSB-1, 2, 51, 52, 851, 951 SB-2, 10, 20, 51, 52	E 7/2, E 7/4, E 7/5, E 7/5A, E 7/6	SLIVER LAP-E 2/4, E 2/4A
D-10, D20, D22, D24, D30, D40, D40C, D41, D45, D221, D50	E 60, E 60H, E 62, E 65, E 66, E 70, E 72, E 75, E 80, E 86	RIBBEN LAP-E 4/1, E 4/1A UNILAP-E 5/3, E 30, E 32
TD 02, TD 03, TD 07, TD 08, TD 09		OMEGA LAP-E 35 AND LH 10, LH-15
D 05, D 06, LD2, (Old Model) LD2 (New Model), LDA/Z DO2-S-(3 BRG), LDF-3	LK 250, LK 54, LK 64, LK 64Z, LK 69	
DX-400, DX-500, DX-600, DYH-500, DX-7LT, DX-8LT, DFK-2CD	VC-5, VC-250, VC-300, VC-500 CM 10, CM 100	DY 5, SL-100, TS-100
CHINESE-FA-316, FA-306, DZ-2C	FA 266, HOWA HZ	JSFA-360A

COTS : CUSTOMER CHOICE

ACCOTEX / BERKOL / INARCO / PRECITEX / YAMAUCHI

Compatible for DRAW FRAME ROLLERS

TD - 03 / TD 08 (Greasing Type)
BRD 23 x 34 x 185



D30 / D40 / D45 / D221
BRD 26 x 38 x 160



RSB 851 / 951
BRD 26 x 38 x 150



DX 600
BRD 23 x 34 x 180



Compatible for **DRAW FRAME ROLLERS**

DX 500
BRD 22 x 34 x 180



D26 / D50 (Greasing Type)
BRD 26 X 38 X 160



LD - 2 OLD MODEL
BRD 26 x 38 x 160



DO2S (3 Bearing)
BRD 20 x 40 x 210



FA 306 BRD 19 x 33 x 180
22 x 37 x 180



LDF 3 / LDB 3 (Greasing Type)
BRD 26 x 38 x 150

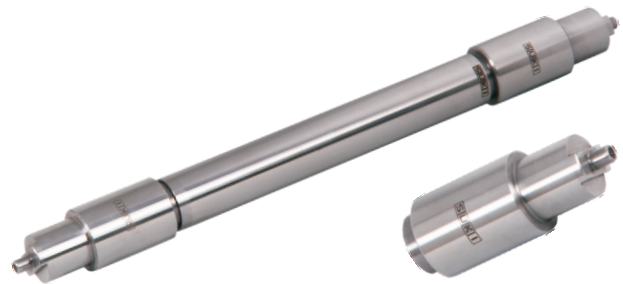

LR DO 6
BRD 25.3 / 26 x 39 x 186



DX 8 LT BRD 26 x 38 x 160
23 x 34 x 160

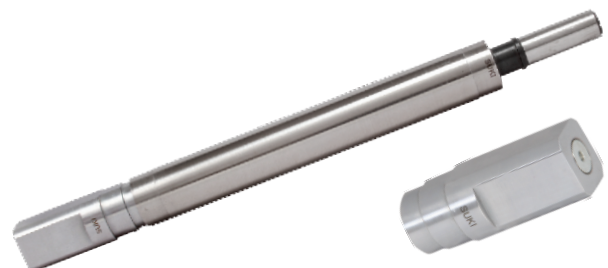

Compatible for **COMBER DETACHING ROLLERS**

LR E 7 / 5 A
BRD 15.92 x 24.5 x 348



LK - 64
BRD 15.92 x 24.5 x 338



Compatible for **COMBER DRAW BOX ROLLERS**

E 65
BRD 30 x 45 x 200



E 60H, E 62
BRD 26 x 39 x 200



Compatible for **LAP FORMERS**

E 5/3, E 32, UNILAP
BRD 26 x 40 x 300



DY5
BRD 30 x 45 x 300



Compatible for **RING FRAME ARBORS & SPEED FRAME ARBORS**



COTS SIZE FOR TOP ROLLERS - PREPARATORY

DRAW FRAME ROLLER	COT SIZE	Glue on cot		Alu. core Cot		
		Precitex	Inarco	Accotex	Precitex	Inarco
RSB 851, RSB 951, RSB 1, RSB 2, SB 2, SB 51 & SB 52	D26 x D38 x 150			Black - 70 Green - 80 Grey - 83	Black - 78 Pink - 83	Blue - 85 Black - 78 Grey - 83
Vouk SH 802 - Dia.30 Vouk SH 802 - Dia.23.1	D30 x D45 x 175 D23.1 x D34/38 x 175	Grey - 83 Grey - 83		Grey - 83 Grey - 83	Grey - 83 Grey - 83	Grey - 83 Grey - 83
Vouk VS - 4A - Dia.30 Vouk VS - 4A - Dia.23.1	D30 x D45 x 210 D23.1 x D38 x 220			Grey - 83 Grey - 83	Grey - 83 Grey - 83	Grey - 83
Cherry / Toyoda-USC 600 DX 600	D23 x D34 x 180			Black - 70 Grey - 83	Grey - 83	Grey - 83
Cherry Hara DX 500	D22 x D34 x 180			Grey - 83		Grey - 83
RSB - D30, D35, D40, D45 & D221	D26 x D38 x 160			Black - 70 Green - 80 Grey - 83	Grey - 83 Black - 78	Grey - 83 Black - 78 Blue - 85
Texmaco Howa DFK-2CD	D24 x D34 x 180		Grey - 83	D.Brown - 70 Green - 80 Grey - 83	Grey - 83	
LR DO/2S or TD 302	D20 x D40 x 210	Grey - 83	Blue - 85	Grey - 83	L- Pink - 83	
LR DO/6	D26 x D39 x 186	Grey - 83	Grey - 83	Grey - 83		
Padmatex 720 (4 over 3)	D23 x D34 x 160	Grey - 83	Grey - 83 Blue - 85	Grey - 83		
COMBER DETACHING ROLLER						
LR E7/4, LK 250	D18 x D24 x 324	D-Green - 65	Violet - 68	Green - 70		
LK 64, LK54	D15.92 x D24.5 x 338	D-Green - 65	Violet - 68	Green - 70		
E7/5A,E7/6,E60H&E70R	D15.92 x D24.5 x 348				Pink - 65	Violet - 68
Toyoda CM8 / CM10	D16 x D24 x 339		Blue - 65		Pink - 65	
E7/5	D15.92 x D24.5 x 338		Blue - 65		Pink - 65	Violet - 68
Cherry Hara/Toyoda VC 250	D16 x D23 x 340		Violet - 68	Lavender - 63	Pink - 65	
COMBER DRAW BOX ROLLER						
LR E7/4	D28.3 x D37 x 223	Grey - 83	Grey - 83	Grey - 83		
	D32.3 x D44 x 223	Grey - 83	Grey - 83	Grey - 83		
E7/5, E7/5A & E7/6	D30 x D45 x 210			Grey - 83	Grey - 83	Grey - 83
E65, LK54	D30 x D39 x 200			Green - 70	Grey - 83	Grey - 83
LK64, E60H	D26 x D39 x 200					
Cherry Hara / Toyoda VC 250	D22 x D31 x 210				Grey - 83	Grey - 83
LAP FORMER ROLLER						
E2/4A Sliver Lap	D32.3 x D44 x 306	Grey - 83	Grey - 83			
	D28.3 x D37 x 306	Grey - 83	Grey - 83			
E4/1A Ribbon Lap	D32.3 x D41 x 306	Grey - 83	Grey - 83			
E5/3 & E30 Unilap	D26xD40x300			Grey - 83	Grey - 83	
E35 OMEGA Lap	D26 x D40 x 300			Grey - 83	Grey - 83	
LH 10	D26 x D39 x 300			Grey - 83	Grey - 83	

RING FRAME, SPEED FRAME & COMPACT SPINNING ARBORS

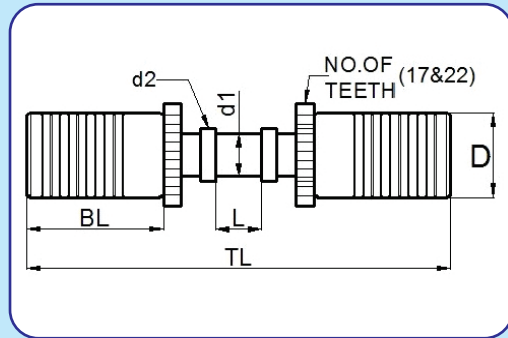
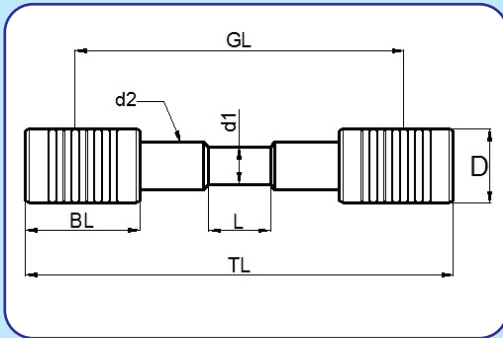
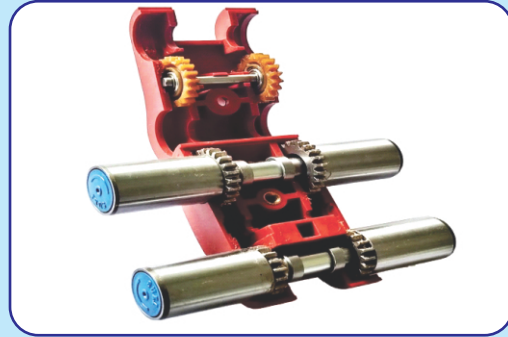

Suki Product No	Compatible for Ring Frame Models	D	GL	TL	BL	d1	d2	L
SUKI-1970-16-30	DJ 50 & KTTM FRONT & BACK, PK 225	19	70	100	30	9.5	11.35	16.2
SUKI-1975-16-30		19	75	105	30	9.5	11.35	16.2
SUKI-1970-20-30	LR6 & LR G5/1	19	70	100	30	10	11.35	20.2
SUKI-1975-20-30		19	75	105	30	10	11.35	20.2
SUKI-1970-RG-30	DJ5 FRONT & BACK	19	70	104	34	8.9	10	R6.2
SUKI-1970-20-28-30	G30, G33, K44 & K45	19	70	100	30	10.0	12	20

Suki Product No	Compatible for Speed Frame Models	D	GL	TL	BL	d1	d2	L
SUKI-19110-22-40	FL16 DRAFTING FRONT & BACK	19	110	150	40	11	12.6	22.2
SUKI-19110-28-40	FL16 DRAFTING MIDDLE	19	110	150	40	11	12.6	28.2

Suki Product No	Compatible for Compact Spinning Models	D	No of Teeth	TL	BL	d1	d2	L
SUKI-701917K	COMPACT SPINNING	19	17	95	31	9.5	12	10.3
SUKI-701922K	COMPACT SPINNING	19	22	95	31	9.5	12	10.3

Custom made ARBORS are also available

Factory & Admn. Office



Machine Shop



Cots Mounting Machines



R & D Team



PRODUCTS :

Preparatory

- ✧ Draw Frame
- ✧ Comber Detaching
- ✧ Comber Draw Box
- ✧ Lap Former

Finishing

- ✧ Ring Spinning Arbors
- ✧ Speed Frame Arbors
- ✧ Compact Arbors

TECHNOLOGY

- ✧ Suki Top Rollers comes with Technology as OEM standard.
- ✧ New Innovative Multi Row Bearing Technology.
- ✧ Cots Mounting and Grinding facility.

FEATURES OF SUKI TOP ROLLERS

- ✧ Bearings are directly Imported from INA - Germany & IKO - Japan.
- ✧ It is designed to withstand for appropriate specified load.
- ✧ Aerospace Components heat treatment method adopted.
(Wear & Tear will be Minimum in shells and End Bushes)
- ✧ End Bushes with Self locking design.
- ✧ Provision to avoid Fluff accumulation in End Bushes.
- ✧ More Durability and Consistent U%.
- ✧ Custom made TOP ROLLERS are also available.
- ✧ Grease : As per OEM Recommendation



SUKI TEXPARTS PRIVATE LIMITED

Factory & Admin Off : S.F No:61/2,
Plot No : 21, Mahatma Gandhi Road,
S.I.H.S Colony Road,
Neelikonam Palayam (Po),
Coimbatore – 641033 . Tamilnadu, India

Mobile : + 91 77084 88333
+ 91 87540 44138
+ 91 95009 90591



Email : sales@sukirollers.com
prabu@sanmitcard.com
ram@sanmitcard.com

www.sukirollers.com